

MACX MCR-EX-SL-RPSSI-I-UP(-SP)



Supply and input signal conditioner, Ex-i, with wide range supply

Data sheet
103561_en_01

© PHOENIX CONTACT 2020-09-29

1 Description

The repeater power supply is designed for the operation of intrinsically safe (Ex i) measuring transducers and mA current sources installed in a potentially explosive atmosphere.

The 2-wire measuring transducers are supplied with energy, and analog 0/4... 20 mA measured values from the hazardous area are transferred to the non-hazardous area.

You can operate the output of the module actively or passively.

The analog measured value on the Ex or non-Ex side can be overlaid with digital (HART) communication signals and transmitted bidirectionally.

You can toggle additional resistance in the output circuit in order to increase the HART impedance in low-ohmic systems using a switch on the front of the housing.

The power supply has been designed as a wide range supply (UP).

Sockets are integrated into the COMBICON connectors for connecting HART (HHT) communicators.

Features

- 0/4 mA ... 20 mA input, intrinsically safe, [Ex ia], powered and not powered
- Measuring transducer supply voltage > 16 V
- Output 0/4 mA ... 20 mA (active or passive)
- Output 0/1 V ... 5 V
- Wide-range power supply of 24 V ... 230 V AC/DC
- Bidirectional HART signal transmission
- Up to SIL 2 according to IEC/EN 61508
- Safe electrical isolation between input, output, and supply
- Installation in Ex zone 2 permitted
- Plug-in connection terminal blocks, either screw or spring-cage connection technology (Push-in technology)
- Housing width: 17.5 mm



WARNING: Explosion hazard

The device is an item of associated equipment with an EPL [Ga], [Da] (category 1) with "intrinsic safety" type of protection and can be installed in zone 2 potentially explosive areas as an EPL Gc (category 3) device. Intrinsically safe circuits can be led up to zone 0/zone 20. It satisfies the requirements of the following standards. You will find detailed information in the EU Declaration of Conformity, which is enclosed and also available on our website in the latest version:

IEC/EN 60079-0, IEC/EN 60079-11, IEC/EN 60079-15

ABNT NBR IEC 60079-0, ABNT NBR IEC 60079-11, ABNT NBR IEC 60079-15

When installing and operating the device, the applicable safety directives (including national safety directives), accident prevention regulations, as well as general technical regulations must be observed.

Observe the safety notes in the "Safety regulations and installation notes" section.



Make sure you always use the latest documentation.

It can be downloaded from the product at [phoenixcontact.net/products](https://www.phoenixcontact.net/products).

This document is valid for the products listed in the "Ordering data".



2	Table of contents	
1	Description	1
2	Table of contents	2
3	Ordering data	3
4	Technical data	5
5	Safety regulations and installation notes.....	8
	5.1 Installation notes	8
	5.2 Intrinsic safety.....	8
	5.3 Installation in Zone 2.....	8
	5.4 Potentially dust-explosive areas	9
	5.5 Safety-related applications (SIL).....	9
	5.6 UL note	9
6	Installation	10
	6.1 Connection notes	10
	6.2 Electrostatic discharge.....	10
	6.3 Structure	10
	6.4 Basic circuit diagram with connection terminal blocks	11
	6.5 Input (intrinsically safe).....	11
	6.6 Output current (without HART communication)	11
	6.7 Output current (with HART communication).....	11
	6.8 HART communication.....	11
	6.9 Output - voltage.....	11
	6.10 Power supply.....	11
	6.11 Dimensions	12
	6.12 Mounting	12
	6.13 Connecting the cables	12
	6.14 Startup.....	12
	6.15 Level conversion	13
7	Comparison of the safety data	14
8	Safety-related applications	15
	8.1 Safety function.....	15
	8.2 Safety integrity requirements	15
	8.3 Conditions	15
	8.4 Installation and startup	16
	8.5 Notes on operation.....	16
	8.6 Recurring checks.....	17
	8.7 Repair.....	17
	8.8 Standards.....	18
	8.9 Abbreviations	18

3 Ordering data

Description	Type	Order No.	Pcs./Pkt.
Ex i repeater power supply and input isolating amplifier, HART Sends fed or active 0/4-20 mA signals from the Ex area to a load (active or passive) to the safe area. Electrical 3-way isolation; SIL 2, wide range power supply.	MACX MCR-EX-SL-RPSSI-I-UP	2865793	1
Ex i repeater power supply and input isolating amplifier, HART Sends fed or active 0/4-20 mA signals from the Ex area to a load (active or passive) to the safe area. Electrical 3-way isolation; SIL 2, wide range power supply.	MACX MCR-EX-SL-RPSSI-I-UP-SP	2924029	1
Accessories	Type	Order No.	Pcs./Pkt.
USB HART modem cable for communication between a PC and HART devices, cable length: 1m.	GW HART USB MODEM	1003824	1
Plastic label, Sheet, white, unlabeled, can be labeled with: BLUEMARK ID COLOR, BLUEMARK ID, BLUEMARK CLED, PLOTMARK, CMS-P1-PLOTTER, mounting type: adhesive, lettering field size: 11 x 9 mm, Number of individual labels: 10	UC-EMLP (11X9)	0819291	10
Plastic label, can be ordered: by sheet, white, labeled according to customer specifications, mounting type: adhesive, lettering field size: 11 x 9 mm	UC-EMLP (11X9) CUS	0824547	1
Plastic label, Sheet, yellow, unlabeled, can be labeled with: BLUEMARK ID COLOR, BLUEMARK ID, BLUEMARK CLED, PLOTMARK, CMS-P1-PLOTTER, mounting type: adhesive, lettering field size: 11 x 9 mm, Number of individual labels: 10	UC-EMLP (11X9) YE	0822602	10
Plastic label, can be ordered: by sheet, yellow, labeled according to customer specifications, mounting type: adhesive, lettering field size: 11 x 9 mm	UC-EMLP (11X9) YE CUS	0824548	1
Plastic label, Sheet, silver, unlabeled, can be labeled with: BLUEMARK ID COLOR, BLUEMARK ID, BLUEMARK CLED, PLOTMARK, CMS-P1-PLOTTER, mounting type: adhesive, lettering field size: 11 x 9 mm, Number of individual labels: 10	UC-EMLP (11X9) SR	0828094	10
Plastic label, can be ordered: by sheet, silver, labeled according to customer specifications, mounting type: adhesive, lettering field size: 11 x 9 mm, Number of individual labels: 10	UC-EMLP (11X9) SR CUS	0828098	1
Plastic label, Card, white, unlabeled, can be labeled with: BLUEMARK ID COLOR, BLUEMARK ID, THERMOMARK PRIME, THERMOMARK CARD 2.0, THERMOMARK CARD, mounting type: adhesive, lettering field size: 11 x 9 mm, Number of individual labels: 135	US-EMLP (11X9)	0828789	10

Accessories	Type	Order No.	Pcs./Pkt.
Plastic label, Card, yellow, unlabeled, can be labeled with: BLUEMARK ID COLOR, BLUEMARK ID, THERMOMARK PRIME, THERMOMARK CARD 2.0, THERMOMARK CARD, mounting type: adhesive, lettering field size: 11 x 9 mm, Number of individual labels: 135	US-EMLP (11X9) YE	0828871	10
Plastic label, Card, silver, unlabeled, can be labeled with: BLUEMARK ID COLOR, BLUEMARK ID, THERMOMARK PRIME, THERMOMARK CARD 2.0, THERMOMARK CARD, mounting type: adhesive, lettering field size: 11 x 9 mm, Number of individual labels: 135	US-EMLP (11X9) SR	0828872	10
Device marker, Sheet, white, unlabeled, can be labeled with: TOPMARK NEO, TOPMARK LASER, mounting type: adhesive, lettering field size: 11 x 9 mm, Number of individual labels: 255	LS-EMLP (11X9) WH	0831678	10
Device marker, Sheet, yellow, unlabeled, can be labeled with: TOPMARK NEO, TOPMARK LASER, mounting type: adhesive, lettering field size: 11 x 9 mm, Number of individual labels: 255	LS-EMLP (11X9) YE	0831732	10
Device marker, Sheet, silver, unlabeled, can be labeled with: TOPMARK NEO, TOPMARK LASER, mounting type: adhesive, lettering field size: 11 x 9 mm, Number of individual labels: 255	LS-EMLP (11X9) SR	0831705	10
Test plugs, with solder connection up to 1 mm ² conductor cross section, color: gray	MPS-MT	0201744	10
Insulating sleeve, color: black	MPS-IH BK	0201731	10
Insulating sleeve, color: gray	MPS-IH GY	0201728	10
Insulating sleeve, color: green	MPS-IH GN	0201702	10
Insulating sleeve, color: yellow	MPS-IH YE	0201692	10
Insulating sleeve, color: blue	MPS-IH BU	0201689	10
Insulating sleeve, color: red	MPS-IH RD	0201676	10
Insulating sleeve, color: white	MPS-IH WH	0201663	10

4 Technical data

Input data Repeater power supply operation	
Description of the input	Active current input, intrinsically safe
Current input signal	4 mA ... 20 mA
Transmitter supply voltage	> 16 V (20 mA) > 15.3 V (22.5 mA)
Input data Signal conditioner operation	
Description of the input	Passive current input, intrinsically safe
Current input signal	0 mA ... 20 mA 4 mA ... 20 mA
Voltage drop	< 3.5 V (in input isolating amplifier operation)
Output Signal conditioner operation	
Output description	Current output (active and passive)
Voltage output signal	0 V ... 5 V (internal resistance, 250 Ω, 0.1%)
Current output signal	0 mA ... 20 mA (active) 4 mA ... 20 mA (active) 0 mA ... 20 mA (14 ... 26 V ext. source voltage) 4 mA ... 20 mA (14 ... 26 V ext. source voltage)
Load/output load current output	< 600 Ω (20 mA) < 525 Ω (22.5 mA)
Output ripple	< 20 mV _{rms}
Output behavior in the event of an error as per NE 43	0 mA (Cable break in the input) 0 mA (Cable short-circuit in the input)
General data	
Supply voltage range	24 V ... 230 V AC/DC (-20 %/+10 %, 50/60 Hz)
Max. current consumption	< 80 mA (24 V DC / 20 mA)
Power dissipation	< 1.6 W (24 V DC / 20 mA)
Transmission error, typical	< 0.05 % (of final value)
Maximum transmission error	< 0.1 % (of final value)
Maximum temperature coefficient	< 0.01 %/K
Step response (10-90%)	< 600 μs (for 4 mA ... 20 mA step)
HART function	Yes
Protocols supported	HART
Signal bandwidth	as per HART specifications
Degree of protection	IP20 (not assessed by UL)
Flammability rating according to UL 94	V0 (Housing)
Overvoltage category	II
Degree of pollution	2
Status display	Green LED (supply voltage)
Dimensions W/H/D	17.5 mm / 112.8 mm / 113.7 mm (MACX MCR-EX-SL-RPSSI-UP) 17.5 mm / 117.7 mm / 113.7 mm (MACX MCR-EX-SL-RPSSI-UP-SP)
Type of housing	PA 6.6-FR gray

Ambient conditions

Ambient temperature (operation)	-20 °C ... 60 °C (Any mounting position)
Ambient temperature (storage/transport)	-40 °C ... 80 °C
Permissible humidity (operation)	10 % ... 95 % (non-condensing)
Maximum altitude for use above sea level	≤ 2000 m

Electrical isolation

Input/output/power supply	
Rated insulation voltage	300 V _{rms}
Test voltage	2.5 kV AC (50 Hz, 1 min.)
Insulation	Safe isolation in accordance with IEC/EN 61010-1
Input/output	
Electrical isolation	375 V (Peak value in accordance with IEC/EN 60079-11)
Input/power supply	
Electrical isolation	375 V (Peak value in accordance with IEC/EN 60079-11)

Safety data in accordance with ATEX and IECEx Repeater power supply operation

Max. output voltage U _o	25.2 V
Max. output current I _o	93 mA
Max. output power P _o	587 mW
Max. external inductivity L _o / Max. external capacitance C _o simple circuit	IIB : 4 mH / 820 nF
Max. external inductivity L _o / Max. external capacitance C _o simple circuit	IIC : 2 mH / 107 nF
Safety-related maximum voltage U _m	253 V AC/DC (Supply terminals) 253 V AC (Output terminals) 125 V DC (Output terminals)

Safety data in accordance with ATEX and IECEx Signal conditioner operation

Max. voltage U _i	≤ 30 V
Max. current I _i	≤ 150 mA
Max. internal inductance L _i	negligible
Max. internal capacitance C _i	negligible
Safety-related maximum voltage U _m	253 V AC/DC (Supply terminals) 253 V AC (Output terminals)

Conformance with EMC directive

Noise immunity according to EN 61000-6-2 When being exposed to interference, there may be minimal deviations.

Noise emission according to EN 61000-6-4

Conformance/Approvals

CE and EN 61326	CE-compliant
ATEX (BVS 08 ATEX E 094 X)	ⓧ II (1) G [Ex ia Ga] IIC/IIB ⓧ II (1) D [Ex ia Da] IIIC ⓧ II 3(1) G Ex nA [ia Ga] IIC/IIB T4 Gc
IECEX (IECEX BVS 08.0035X)	[Ex ia Ga] IIC/IIB [Ex ia Da] IIIC Ex nA [ia Ga] IIC/IIB T4 Gc
CCC / China-Ex (NEPSI GYJ20.1310X)	[Ex ia Ga] IIC [Ex iaD] Ex nA [ia Ga] IIC/IIB T4 Gc
INMETRO (DNV 18.0138 X)	[Ex ia Ga] IIC/IIB [Ex ia Da] IIIC Ex nA [ia Ga] IIC/IIB T4 Gc
EAC Ex (RU C-DE.AB72.B.00093/19)	EAC Ex [Ex ia Ga] IIC EAC Ex [Ex ia Da] IIIC
UL, USA/Canada (UL, C.D.-No 83104549)	Class I Div 2; IS for Class I, II, III Div 1
Safety Integrity Level (SIL, IEC 61508)	2

5 Safety regulations and installation notes

5.1 Installation notes

- The device is an item of associated equipment with an EPL [Ga], [Da] (category 1) with "intrinsic safety" type of protection and can be installed in zone 2 potentially explosive areas as an EPL Gc (category 3) device. Intrinsically safe circuits can be led up to zone 0/ zone 20. It satisfies the requirements of the following standards. Comprehensive details are to be found in the EU Declaration of Conformity, which is enclosed and also available on our website in the latest version: IEC/EN 60079-0, IEC/EN 60079-11, IEC/EN 60079-15 GB 3836.1, GB 12476.1, GB 3836.4, GB 12476.4, GB 3836.8, GB 3626.20 ABNT NBR IEC 60079-0, ABNT NBR IEC 60079-11, ABNT NBR IEC 60079-15
- Installation, operation, and maintenance may only be carried out by qualified electricians. Follow the installation instructions as described. When installing and operating the device, the applicable regulations and safety directives (including national safety directives), as well as general technical regulations, must be observed. For the safety data, refer to this document and the certificates (EU examination certificate and other approvals if appropriate).
- The device must not be opened or modified. Do not repair the device yourself, replace it with an equivalent device. Repairs may only be carried out by the manufacturer. The manufacturer is not liable for damage resulting from violation.
- The IP20 degree of protection (IEC/EN 60529) specifies that the device is intended for use in a clean and dry environment. Do not subject the device to mechanical and/or thermal stress that exceeds the specified limits.
- Only use the device up to a pollution degree 2 in accordance with IEC 60664-1.
- The connected non-intrinsically safe circuits may have a maximum overvoltage category II in accordance with IEC 60664-1.
- The device must be stopped if it is damaged, has been subjected to an impermissible load, stored incorrectly, or if it malfunctions.
- The device complies with the EMC regulations for industrial areas (EMC class A). When using the device in residential areas, it may cause radio interference.
- A SELV/PELV power supply unit with a nominal voltage of 24 V DC (max. 30 V DC) is needed for the external power supply of the device.
- The products must be installed in accordance with all applicable standards for electrical systems in potentially explosive areas.

- Only use copper connecting cables.

5.2 Intrinsic safety

- The device is approved for intrinsically safe (Ex i) circuits up to zone 0 (gas) and zone 20 (dust) in the Ex area. The safety technology values for intrinsically safe equipment and the connecting lines must be observed for the hook-up process (IEC/EC 60079-14) and the values specified in this installation note and/or the EU examination certificate must be observed.
- When carrying out measurements on the intrinsically safe side, observe the relevant regulations regarding the connection of intrinsically safe equipment. Use only these approved measuring devices in intrinsically safe circuits.
- If the device was used in circuits which are not intrinsically safe, it is forbidden to use it again in intrinsically safe circuits. Label the device clearly as being not intrinsically safe.

5.3 Installation in Zone 2

- Observe the specified conditions for use in potentially explosive areas. Install the device in a suitable approved housing with at least IP54 protection that meets the requirements of IEC/EN 60079-15 or another type of protection in accordance with ABNT NBR IEC 60079-0, Section 1. Also observe the requirements of IEC/EN 60079-14.
- In potentially explosive areas, it is only permissible to snap the device on or off the DIN rail connector and to connect or disconnect non-intrinsically-safe cables when the power is disconnected.
- The device must be stopped and immediately removed from the Ex area if it is damaged, was subject to an impermissible load, stored incorrectly or if it malfunctions.

5.4 Potentially dust-explosive areas

- The device is not suitable for installation in zone 22.
- If you nevertheless intend to use the device in zone 22, you must install it in a housing according to IEC/EN 60079-31. Observe the maximum surface temperatures in this case. Adhere to the requirements of IEC/EN 60079-14.
- Connection to the intrinsically safe circuit in areas with a danger of dust explosions (zone 20, 21 or 22) is only permitted if the equipment connected to this circuit is approved for this zone (e.g., category 1D, 2D or 3D).

5.5 Safety-related applications (SIL)

When using the device in safety-related applications, observe the instructions in “Safety-related applications”, as the requirements differ for safety-related functions.

5.6 UL note

The safety specifications, which are based on UL approval, can be found in the “Control Drawing”. The “Control Drawing” is part of the package slip.

6 Installation

6.1 Connection notes



WARNING: Electrical danger due to improper installation

Observe the connection notes for safe installation in accordance with EN/UL 61010-1:

- Disconnecting devices and branch circuit protection with suitable AC or DC rating shall be provided in the building installation.
- The device is intended for installation in a control cabinet or in a comparable enclosure. The device may only be operated when it has been installed. The control cabinet must meet the requirements of UL/IEC 61010-1 in terms of protection against spread of fire and protection against electric shock or burn.
- Provide a switch/circuit breaker close to the device that is labeled as the disconnect device for this device (or the entire control cabinet).
- Provide overcurrent protection ($I \leq 16 \text{ A}$) within the installation.
- To protect the device against mechanical or electrical damage, install it in suitable housing with an appropriate degree of protection according to IEC/EN 60529.
- During installation, servicing, and maintenance work, disconnect the device from all effective power sources, provided you are not dealing with SELV or PELV circuits.
- If the device is not used as described in the documentation, the intended protection can be negatively affected.
- Before configuring settings using DIP switch, make sure the device has been de-energized.
- Thanks to its housing, the device has basic insulation to the neighboring devices, for 300 Veff. If several devices are installed next to each other, this has to be taken into account, and additional insulation has to be installed if necessary! If the neighboring device is equipped with basic insulation, no additional insulation is necessary.
- The voltages applied at the input, output, and power supply are extra-low voltages (ELV). Depending on the application, the switching voltage at the relay output may be a hazardous contact voltage ($> 30 \text{ V AC/} > 60 \text{ V DC}$). Safe electrical isolation from other connections exists for such cases.



WARNING: Explosion hazard

If the device has been used in non-intrinsically safe circuits, it must not be used again in intrinsically safe circuits.

The device must be clearly marked as non-intrinsically safe.

6.2 Electrostatic discharge



NOTE: Electrostatic discharge

The device contains components that can be damaged or destroyed by electrostatic discharge. When handling the device, observe the necessary safety precautions against electrostatic discharge (ESD) according to EN 61340-5-1 and IEC 61340-5-1.

6.3 Structure

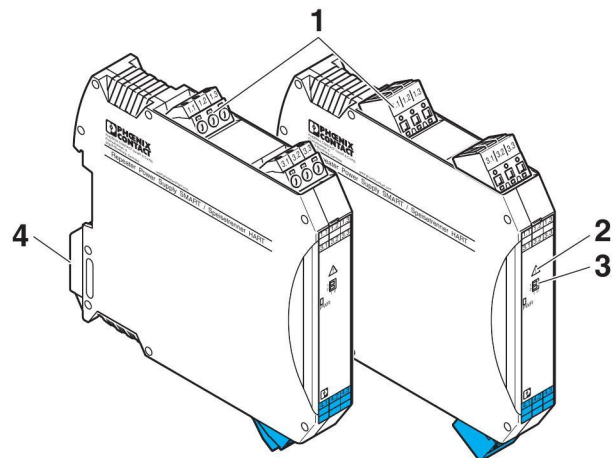

Figure 1 Structure

- 1 COMBICON plug-in, screw, or push-in connection terminal with integrated test socket
- 2 DIP switch (S1: toggling current/voltage output; S2: resistance in the output circuit to increase HART impedance)
- 3 Green "PWR" LED, power supply
- 4 Snap-on foot for DIN rail mounting

6.4 Basic circuit diagram with connection terminal blocks

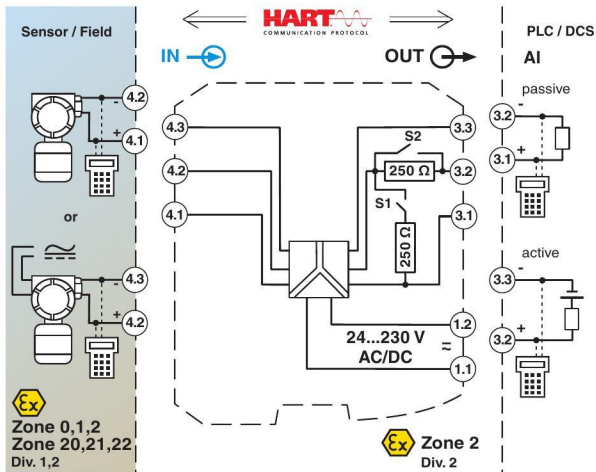

Figure 2 Basic circuit diagram

6.5 Input (intrinsically safe)

- Repeater power supply operation (feeding input for 2-conductor transmitter or 2-conductor measuring transducer) on terminal 4.1 (+) and 4.2 (-)
- Input signal conditioner operation (non-feeding input for 4-conductor transmitter or current sources) on terminals 5.1 (+) and 5.2 (-)

6.6 Output current (without HART communication)

Operating mode	Connection of input card to terminal	DIP	
		S1	S2
Source – passive input card	3.1 (+) and 3.2 (-)	I	II
Drain – active input card	3.2 (+) and 3.3 (-)	I	II

6.7 Output current (with HART communication)

Operating mode	Circuit impedance	Connection		DIP	
		Input board	HART communicator	S1	S2
Source – passive input card	$\geq 250 \Omega$	3.1 (+) and 3.2 (-)	3.1 and 3.2	I	II
	$< 250 \Omega$	3.1 (+) and 3.2 (-)	3.2 and 3.3	I	I
Drain – active input card	$\geq 250 \Omega$	3.2 (+) and 3.3 (-)	3.2 and 3.3	I	II
	$< 250 \Omega$	3.2 (+) and 3.3 (-)	-	I	II

6.8 HART communication

HART communicators (HHT) can be connected as shown in the basic circuit diagram. Test sockets (diameter 2.3 mm) have been integrated for this purpose.

6.9 Output - voltage

Operating mode	Connection of input card to terminal	DIP	
		S1	S2
Source – passive input card	3.1 (+) and 3.2 (-)	II	II

6.10 Power supply

You can feed in the supply voltage via the connection terminal blocks 1.1 (+) and 1.2 (-) (24 V DC ... 230 V DC).

6.11 Dimensions

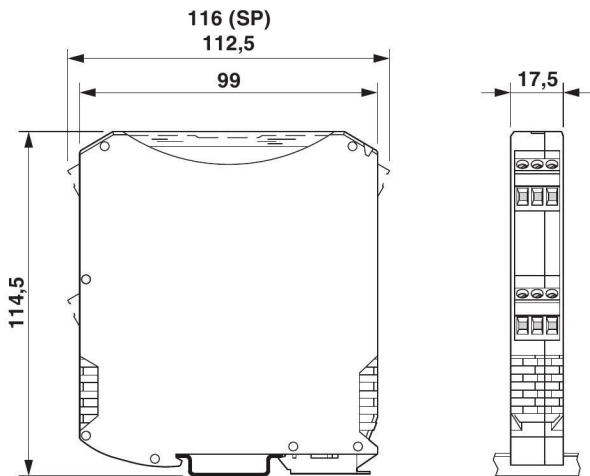

Figure 3 Dimensions

6.12 Mounting

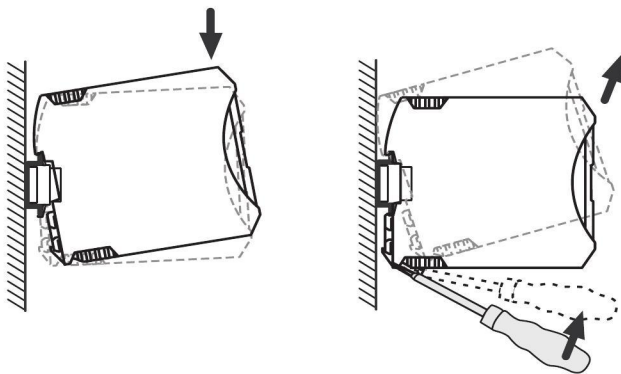

Figure 4 Mounting and removing

- Mount the device on a 35 mm DIN rail according to EN 60715.
- Install the module in a suitable housing to meet the requirements for the protection class.

6.13 Connecting the cables

Screw Connection

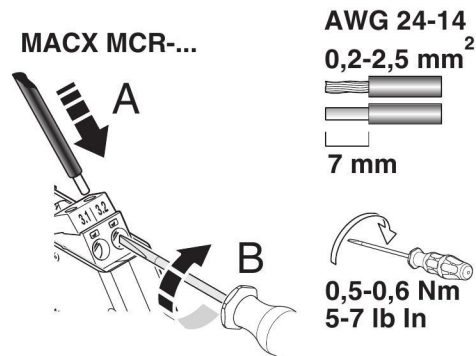

Figure 5 Screw connection

- Strip the wire by approximately 7 mm and crimp ferrules to the end of the wires.
- Insert the wire into the corresponding connection terminal block.
- Use a screwdriver to tighten the screw in the opening above the connection terminal block. Tightening torque: 0.6 Nm

Push-in connection:

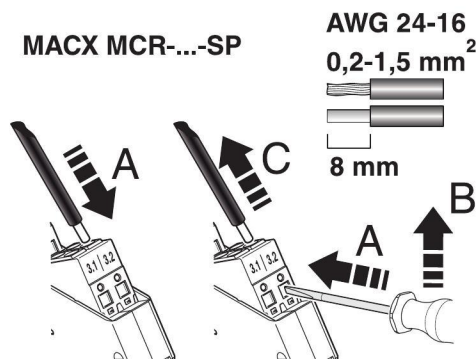

Figure 6 Push-in connection

- Strip the wire by approximately 8 mm and crimp ferrules to the end of the wires.
- Insert the wire into the corresponding connection terminal block.
- Push in the pushbutton with a screwdriver to release.

6.14 Startup

- Before startup, check that the device is operating and wired correctly, in particular with regard to the wiring and marking of the intrinsically safe circuits.

6.15 Level conversion

Level conversion is not provided between input and output.

4 ... 20 mA input signals therefore become 4 ... 20 mA output signals.

In the same way, active input signals of 0 ... 20 mA become electrically isolated 0 ... 20 mA output signals.

7 Comparison of the safety data



WARNING: Explosion hazard
Compare the safety data before connecting a device located in the Ex i area to this device.

Provide proof of intrinsic safety according to standard IEC/EN 60079-14 and other national standards and installation specifications, if applicable.

Safety data

Field devices	U_i, I_i, P_i, L_i, C_i
Ex repeater power supply	U_o, I_o, P_o, L_o, C_o

The values for U_o, I_o, P_o, L_o, C_o are to be found under "Safety data in accordance with ATEX and IECEx" in the "Technical data" section.

Example for proof of intrinsic safety

Data	Condition
$U_i \geq U_o$	-
$I_i \geq I_o$	-
$P_i \geq P_o$	-
$L_i + L_c \leq L_o$	$L_i < 1\% \text{ of } L_o \text{ or } C_i < 1\% \text{ of } C_o$
$C_i + C_c \leq C_o$	
$L_i + L_c \leq 0.5 L_o$	$L_i \geq 1\% \text{ of } L_o \text{ and } C_i \geq 1\% \text{ of } C_o$
$C_i + C_c \leq 0.5 C_o$	

L_c and C_c depend on the cables used.

Proof of intrinsic safety (simple intrinsically safe circuit)

In a simple intrinsically safe circuit without external concentrated capacitances (C_i) and without external concentrated inductances (L_i), the full values of C_o and L_o can be exploited (see "Safety data as per ATEX" in the section "Technical data").

Proof of intrinsic safety (mixed intrinsically safe circuit)

Condition for the mixed intrinsically safe circuit with external concentrated capacitances (C_i) and/or external concentrated inductances (L_i):

- $L_i < 1\% \text{ of } L_o \text{ or } C_i < 1\% \text{ of } C_o$

Here, the full values of C_o and L_o can also be exploited (see "Safety data as per ATEX" in the section "Technical data").

- $L_i \geq 1\% \text{ of } L_o \text{ and } C_i \geq 1\% \text{ of } C_o$

Values of 50% of C_o and L_o are to be used here:

- $C_i + C_c \leq 0.5 C_o$
- $L_i + L_c \leq 0.5 L_o$

To implement longer cables, you can also use the certified value pairs as an alternative to the values reduced by 50%; they can be found under "Safety data in accordance with ATEX" in the "Technical data" section.

8 Safety-related applications

The following notes apply for the devices:

Designation	Order No.
MACX MCR-EX-SL-RPSSI-I-UP	2865793
MACX MCR-EX-SL-RPSSI-I-UP-SP	2924029
MACX MCR-SL-RPSSI-I-UP	2865968
MACX MCR-SL-RPSSI-I-UP-SP	2924210

The safety-related repeater power supplies and signal conditioners listed above are certified as conforming to DIN EN 61508-1:2002. Test certificate: BVS Pb 09/08.

8.1 Safety function

The safety function of the device involves the electrically isolated forwarding of a 4 ... 20 mA standard signal with a maximum deviation of 5 %.

Safe state and error definition

Output values outside the range of 3.6 mA ... 21 mA are considered the safe state, which is detected by the subsequent controller.

Safe failures in the device are therefore those errors where the device sends an output signal that deviates from the input signal by no more than 5 %.

Dangerous undetectable failures are errors where the device does not follow a change in the input signal or deviates from the input signal by more than 5% and is not outside the range.

Dangerous, detectable failures are those that send a signal outside the range (< 3.6 mA and > 21 mA).

8.2 Safety integrity requirements

Error rates

- Type A device (according to IEC/EN 61508-2)
- Safety integrity level (SIL) 2
- HFT 0
- MTTR 24 h
- 1oo1 architecture
- Ambient temperature 40°C

Operation as a repeater power supply

λ_{SU}	λ_{SD}	λ_{DU}	λ_{DD}	SFF	DC _D
557.7	0	58.3	0	90.55 %	0 %

The total failure rate is 622 FIT.

The MTBF is 183 years.

The average probability of the specified function failing on demand for “low demand” mode and the probability of a dangerous failure per hour for “continuous demand” mode are calculated based on the failure rates.

PFD_{avg} values

T [PROOF]	1 year	3 years	4 years
PFD _{avg}	$2.53 \cdot 10^{-4}$	$7.66 \cdot 10^{-4}$	$1.02 \cdot 10^{-3}$

$$PFH = 5.83 \cdot 10^{-8}/h$$

The requirements for the PFH value for a SIL 2 system are therefore met.

The values in the middle column mean that the calculated PFD_{avg} values are within the permitted range for SIL 2 in accordance with Table 2 of IEC/EN 61508-1. They meet the requirement to not cover more than 10% of the safety circuit, i.e., they are better than or equal to $1.00 \cdot 10^{-3}$.

The values in the last column mean that the calculated PFD_{avg} values are within the permitted range for SIL 2 in accordance with Table 2 of IEC/EN 61508-1. However, they do not meet the requirement to not cover more than 10% of the safety circuit, i.e., to be better than or equal to $1.00 \cdot 10^{-3}$.

Failure limit

Based on an operating mode with a low demand rate. The percentage of the device at PFH/PFD for the entire safety loop is less than 10%.

Safety circuit according to IEC / EN 61508-1			
Sensor	Device	Processing	Actuator
25 %	< 10 %	15 %	50 %

8.3 Conditions

- The failure rates of the components used remain constant throughout the period of use.
- The propagation of errors by the device in the system is not taken into consideration.
- The failure rates of the external power supply are not taken into consideration.
- The specified error rates are based on an ambient temperature of +40°C. For an ambient temperature of +60°C, the error rates must be multiplied by factor 2.5. Factor 2.5 is based on guide values.

8.4 Installation and startup



NOTE: Installation, operation, and maintenance may only be carried out by professionals.

During installation, observe the instructions in the package slip:

Designation	MNR No.
PACKB.MACX MCR-EX-SL-RPSSI-I-UP(-SP)	9040229

The package slip is supplied with the device. It can also be downloaded at: phoenixcontact.net/products.

Lockable housing with IP54 protection is recommended for the installation of the devices.

- Connect the device according to the installation notes.
- Make sure that the connected sensor and measuring transducer correspond to the intended configuration.
- Check that the device operates correctly with the measuring transducer and sensor connected.
- A calibrated sensor simulator and a calibrated digital multimeter may be required in order to check the device with the measuring transducer connected.
- Start up the safety circuit and check that it operates correctly.

8.5 Notes on operation

In normal operation, only the green LED (PWR) is permanently on.

If a failure occurs during operation, the output signal is usually set to a value outside the “normal” signal range of 3.6 ... 21 mA. The connected SIS should therefore check the validity of the read signal values and initiate appropriate measures in the event of deviations from the normal values.

Make sure that the connected measuring transducers respond to line faults at the sensors.

After being switched off and on again, the required voltages are established in the device. Signal transmission is then performed without further action.

8.6 Recurring checks

The function of the entire safety loop must be checked regularly according to IEC/EN 61508 and IEC/EN 61511.

The intervals for checking are specified by the intervals of each individual device within the safety loop.

It is the operator's responsibility to select the type of checks and the checking intervals in the specified time period.

Checking must be carried out in such a way that the correct function of the safety equipment in conjunction with all components can be verified.

In SIL 2 applications, devices need to be checked at the latest after the maximum maintenance/test interval, if they cover a share of no more than 10% of the total safety circuit.

Possible procedure for recurring checks for discovering dangerous and undetected device failures

A calibrated simulator (0/4 ... 20 mA current) or a sensor simulator and one or ideally two calibrated digital multimeters are required in order to check the devices.

1. Take appropriate steps to prevent incorrect use.
2. Disconnect the safety circuit from further processing.
3. Connect the current simulator to the input of the repeater power supply/signal conditioner, or the sensor simulator to the input of the measuring transducer.
4. Connect the digital multimeters to the input and output of the repeater power supply/signal conditioner.
5. At the input of the device, set a signal in the range from 4 ... 20 mA or at the input of the connected measuring transducer, set a suitable signal with the sensor simulator.
6. Measure the current in the repeater power supply/signal conditioner. The output must be set to the same value.
7. Setting ≤ 3.6 mA or > 21 mA verifies that the subsequent processing can detect signals that are out of range and evaluate them accordingly. If the output value deviates from the input value by more than 3 times the specified class accuracy rating, the device should be checked. In the event of an error, the device should be replaced with an equivalent device.
8. Restore the safety circuit to full functionality.
9. Resume normal operation.

8.7 Repair

The devices have a long service life, are protected against malfunctions, and are maintenance-free.

However, if a device should fail, send it back to Phoenix Contact immediately. The type of malfunction and possible cause must also be stated.

Please use the original packaging or other suitable safe packaging when sending devices back for repairs or recalibration.

Phoenix Contact GmbH & Co. KG
Abteilung Service und Reparatur
Flachmarktstr. 8
32825 Blomberg
GERMANY

8.8 Standards

The devices are developed and tested according to the following standards:

- IEC/EN 61508-1: 2011** Functional Safety of electrical/electronic/programmable electronic safety-related systems - Part 1: General requirements
- IEC/EN 61508-2: 2011** Functional Safety of electrical/electronic/programmable electronic safety-related systems - Part 2: Requirements for electrical/electronic/programmable electronic safety-related systems
- IEC/EN 61326-1: 2006** Electrical equipment for measurement, control and laboratory use - EMC requirements
- IEC/EN 61326-3-2: 2006** Electrical equipment for measurement, control and laboratory use - EMC requirements - Part 3-2: Immunity requirements for safety-related systems and for equipment intended to perform safety-related functions (Functional Safety) - Industrial applications with specified electromagnetic environment

8.9 Abbreviations

Abbreviation		Meaning
DC _D	Diagnostic coverage of dangerous failures	Diagnostic coverage of dangerous failures: $DC_D = \lambda_{DD} / (\lambda_{DU} + \lambda_{DD})$
DC _S	Diagnostic coverage of safe failures	Diagnostic coverage of safe failures: $DC_S = \lambda_{SD} / (\lambda_{SU} + \lambda_{SD})$
FIT	Failure in time	1 FIT = 1 failure/10 ⁹ h
HFT	Hardware fault tolerance	Hardware fault tolerance: ability of a function unit to continue with the execution of a demanded function despite existing faults or deviations
λ_D	Rate of dangerous failures	Proportion of dangerous failures per hour
λ_{DD}	Rate of dangerous detected failures	Proportion of detected dangerous failures per hour
λ_{DU}	Rate of dangerous undetected failures	Proportion of undetected dangerous failures per hour
λ_S	Rate of safe failures	Proportion of safe failures per hour
λ_{SD}	Rate of safe detectable failures	Proportion of detectable safe failures per hour
λ_{SU}	Rate of safe undetectable failures	Proportion of undetectable safe failures per hour
MTBF	Mean time between failures	Mean time between consecutive failures
PFD _{avg}	Average probability of failure on demand	Average probability of dangerous failure on demand of a safety function
PFH _D	Probability of a dangerous failure per hour	Probability of failure per hour for the safety function
SFF	Safe failure fraction	Proportion of safe failures: proportion of failures without the potential to set the safety-related system to a dangerous or impermissible function state
SIL	Safety integrity level	International standard IEC 61508 defines four discrete safety integrity levels (SIL 1 to 4). Each level corresponds to a probability range for the failure of a safety function. The higher the safety integrity level of safety-related systems, the lower the probability that the demanded safety functions will not be performed.